

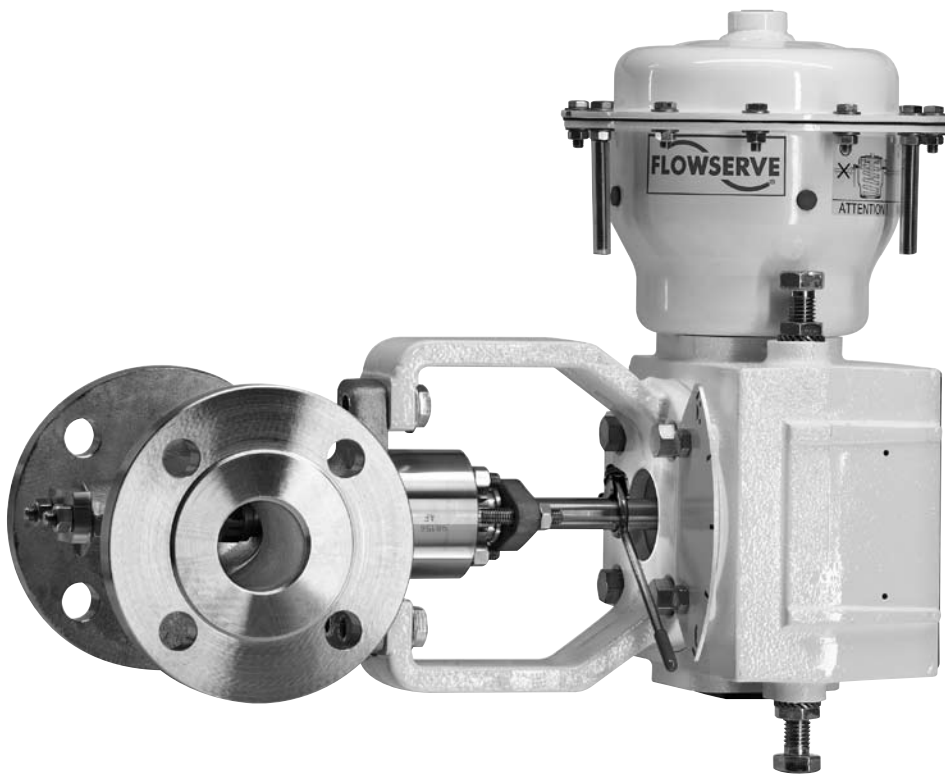

# *USER INSTRUCTIONS*

Valtek MaxFlo 3  
Control Valves

*Installation  
Operation  
Maintenance*



Summary

- 1 GENERAL INFORMATION
- 2 UNPACKING
- 3 INSTALLATION
- 4 QUICK-CHECK
- 5 PREVENTATIVE MAINTENANCE
- 7 VALVE DISASSEMBLY
- 7 BODY REASSEMBLY
- 8 SEAT REPLACEMENT
- 9 ACTUATOR REMOUNTING
- 10 PRINCIPLES OF SHAFT ANTI-BLOWOUT SYSTEM
- 11 MOUNTING ORIENTATION– AIR-TO-OPEN - diaphragm actuator
- 12 MOUNTING ORIENTATION – AIR-TO-CLOSE - diaphragm actuator
- 13 MOUNTING ORIENTATION– AIR-TO-OPEN - cylinder actuator
- 14 MOUNTING ORIENTATION – AIR-TO-CLOSE - cylinder actuator
- 15 PIPE MOUNTING ORIENTATION CODES
- 16 TROUBLESHOOTING

1 GENERAL INFORMATION

1.1 Use

The following instructions are designed to assist in the unpacking, installation, and maintenance as required for Flowserve products. Product users and maintenance personnel should thoroughly review this manual prior to installing, operating, or performing any maintenance. In most cases, Flowserve accessories, actuators and valves are designed for specific applications (e.g. with regard to medium, pressure and temperature). For this reason, they should not be used in other applications without first contacting the manufacturer.

1.2 Applicability

The following instructions are applicable to the maintenance and installation of Flowserve MaxFlo 3 control valves. These instructions cannot claim to cover all details of all possible product variations, nor can they provide information for every possible example of installation, operation or maintenance. This means that the instructions normally include only the directions to be followed by qualified personal using the product for its defined purpose. If there are any uncertainties in this respect, particularly in the event of missing product-related information, clarification must be obtained via the appropriate Flowserve sales office. Flowserve User Manuals are available at [www.flowserve.com](http://www.flowserve.com).

1.3 Terms related to safety

The terms **DANGER, WARNING, CAUTION, NOTE** are used in this document to highlight particular dangers and/or to provide additional information on points which may not be clearly obvious.



**DANGER:** Indicates that death, severe personal injury and/or substantial property damage will occur if proper precautions are not taken.



**WARNING:** Indicates that danger of death or severe personal injury and/or property damage can occur if proper precautions are not taken.



**CAUTION:** Indicates that minor personal injury and/or serious damage to property can occur if the appropriate precautions are not taken.



**NOTE:** Indicates and provides additional technical information which may not be obvious, even to qualified personnel.

Compliance with other notes, which may not be particularly emphasized, with regard to transport, assembly, operation and maintenance and with regard to technical documentation (e.g. in the operating instructions, product documentation, or on the product itself) is essential, in order to avoid faults, which can directly or indirectly cause severe personal injury or property damage..

1.4 Protective clothing

Flowserve products are often used in problematic applications (e.g. under extremely high pressures with dangerous, toxic or corrosive mediums). When performing service, inspection, or repair operations, always ensure that the valve and the actuator are depressurized and that the valve has been cleaned, and that it is free of harmful substances. In such cases, pay particular attention to personal protection (e.g. protective clothing, gloves, glasses etc).

1.5 Qualified personnel

Qualified personnel are people who on account of their education, experience, training, and knowledge of relevant standards, specifications, accident prevention, and operating conditions have been authorized by those responsible for the safety of the plant to perform the necessary work, and recognize and avoid possible dangers.

1.6 Spare Parts

Use only Flowserve original spare parts. Flowserve cannot accept responsibility for any damages that occur from using spare parts or fastening materials from other manufacturers. If Flowserve products (especially sealing materials) have been on store for long periods of time, check them for corrosion or deterioration before putting them into use.

1.7 Service / Repair

To avoid possible injury to personnel or damage to products, safety terms must be strictly adhered to. Modifying this product, substituting non-factory parts, or using maintenance procedures other than those outlined in these Installation, Operation and Maintenance Instructions could drastically affect performance, be hazardous to personnel and equipment, and may void existing warranties. Between the actuator and the valve there are moving parts. To avoid injury, Flowserve provides pinch-point-protection in the form of cover plates, especially where side-mounted positioners are fitted. If these plates are removed for inspection, service or repair special attention is required. After completing work the cover plates must be refitted. Apart from the operating instructions and the obligatory accident prevention directives valid in the country of use, all recognized regulations for safety and good engineering practices must be followed.



**WARNING:** Before products are returned to Flowserve for repair or service, Flowserve must be provided with a certificate that confirms that the product has been decontaminated and is clean. Flowserve will not accept deliveries if a certificate has not been provided (a form can be obtained from Flowserve).

## 1.8 Storage

In most cases, Flowserve products are manufactured from stainless steel. Products not manufactured from stainless steel are provided with an epoxy resin coating. This means that Flowserve products are well protected from corrosion. Nevertheless, Flowserve products must be stored adequately in a clean, dry, environment. Plastic caps are fitted to protect the flange faces and prevent the ingress of foreign materials. These caps should not be removed until the valve is actually mounted into the system.

## 2 UNPACKING

2.1 While unpacking the valve, check the packing list against the materials received. Lists describing the valve and accessories are included in each shipping container.

2.2 When lifting the valve from shipping container, use straps through the yoke legs. Take care to position lifting straps to avoid damage to the tubing and mounted accessories.



**WARNING:** When lifting a valve be aware that the center of gravity may be above the lifting point. Therefore, support must be given to prevent the valve from rotating. Failure to do so can cause serious injury to personnel and damage to the valve and nearby equipment.

2.3 Contact your shipper immediately if there is shipping damage.

2.4 Should any problem arise, call your Flowserve representative.



**DANGER:** Before installation check the order number, serial number, and/or the tag number to ensure that the valve and actuator being installed are correct for the intended application.



**CAUTION:** Do not insulate extensions that are provided for hot or cold services.

## 3 INSTALLATION

3.1 Before installing the valve, clean the pipeline of all contamination, carbon deposits, welding chips, and other foreign material. Carefully clean gasket surfaces to ensure a tight seal. Pipelines must be correctly aligned to ensure that the valve is not fitted under tension.

3.2 Fire protection must be provided by the user.

3.3 Check the direction of fluid flow to ensure that the valve is correctly installed. Flow direction is indicated by the arrow attached to the body. All installation orientations for fitting the valve into the pipeline are defined at the end of this manual.



**DANGER:** To avoid serious injury, keep hands, hair, clothing, etc away from the plug and seat when the valve is working.

3.4 Whenever possible, the valve should be installed so that actuator is in an upright position. Vertical installation of the actuator permits easier valve maintenance.

3.5 Connect the air supply and instrument signal lines. Throttling control valves are equipped with a valve positioner. Connections are marked for the air supply and the instrument signal. Check that the actuator and positioner can withstand the maximum air supply from the network. The required air supply is indicated on a sticker located on the actuator. An air regulator will be necessary in certain cases in order to limit the supply pressure. A filter is recommended unless the air supplied is exceptionally clean and dry (air quality without humidity, oil, or dust as per IEC 770 and ISA-7.0.01). All connections must be completely tight.



**CAUTION:** On valves equipped with air filters, the air filter must point down to perform properly.

3.6 Use the bolts indicated in table I for installing the valve in the pipeline, and then tighten alternately according to good practice. The user must in all cases confirm the capacity of the bolts to ensure a sufficiently tight gasket seal for the expected service conditions.

3.7 Be sure to provide proper overhead clearance for the actuator to allow for disassembly of the actuator from the valve body. Refer to the appropriate to the MaxFlo 3 Technical Bulletin for proper clearances. The MaxFlo 3 Technical Bulletin is available at [www.flowserve.com](http://www.flowserve.com).

Table I: Line Flange Bolting Specifications

Valve size	Nominal Pressure / Rating	MaxFlo 3 flanged Size x Length			MaxFlo 3 flangeless Size x Length		
		Inches	Metric	Qty/ valve	Inches	Metric	Qty/ valve
DN25 1"	ANSI 150	1/2 X 2.62	M12 X 65	8	1/2 X 6.75	M12 X 170	4
	ANSI 300	5/8 X 3.12	M16 X 80	8	5/8 X 6.88	M16 X 175	4
	PN 16		M12 X 70	8		M12 X 175	4
	PN 40		M12 X 70	8		M12 X 175	4
DN40 1 1/2"	ANSI 150	1/2 X 2.88	M12 X 70	8	1/2 X 7.50	M12 X 190	4
	ANSI 300	3/4 X 3.62	M20 X 95	8	3/4 X 8.38	M20 X 215	4
	PN 16		M16 X 80	8		M16 X 200	4
	PN 40		M16 X 80	8		M16 X 200	4
DN50 2"	ANSI 150	5/8 X 3.25	M16 X 85	8	5/8 X 8.38	M16 X 215	4
	ANSI 300	5/8 X 3.5	M16 X 90	16	5/8 X 3.50	M16 X 90	4
					5/8 X 8.50	M16 X 220	6
	PN 16		M16 X 85	8		M16 X 215	4
	PN 40		M16 X 85	8		M16 X 215	4
DN80 3"	ANSI 150	5/8 X 3.62	M16 X 95	8	5/8 X 10.5	M16 X 265	4
	ANSI 300	3/4 X 4.25	M20 X 110	16	3/4 X 4.25	M20 X 110	4
					3/4 X 11.00	M20 X 280	6
	PN 16		M16 X 85	16		M16 X 85	6
					M16 X 255	5	
					M16 X 95	6	
					M16 X 265	5	
DN100 4"	ANSI 150	5/8 X 3.62	M16 X 95	16	5/8 X 3.62	M16 X 95	4
					5/8 X 11.5	M16 X 295	6
	ANSI 300	3/4 X 4.5	M20 X 115	16	3/4 X 4.5	M20 X 115	4
					3/4 X 12.25	M20 X 315	6
	PN 16		M16 X 85	16		M16 X 85	6
						M16 X 285	5
						M20 X 100	6
						M20 X 300	5
DN150 6"	ANSI 150	3/4 X 3.75	M20 X 105	16	3/4 X 3.75	M20 X 105	4
					3/4 X 13.25	M20 X 340	6
	ANSI 300	3/4 X 4.88	M20 X 125	24	3/4 X 4.88	M20 X 125	8
					3/4 X 14.00	M20 X 360	8
	PN 16		M20 X 100	16		M20 X 100	4
						M20 X 335	6
						M24 X 115	4
						M24 X 350	6
DN200 8"	ANSI 150	3/4 X 4.25	M20 X 110	16	3/4 X 4.25	M20 X 360	8
	ANSI 300	7/8 X 5.5	M22 X 140	24	7/8 X 5.5	M22 X 140	4
					7/8 X 15.19	M22 X 390	10
	PN 16		M20 X 100	24		M20 X 100	8
						M20 X 350	8
						M27 X 135	8
						M27 X 385	8
DN250 10"	ANSI 150	7/8 X 4.62	M22 X 120	24			
	ANSI 300	1 X 6.25	M24 X 155	32			
	PN 16		M24 X 110	24			
	PN 40		M30 X 150	24			
DN300 12"	ANSI 150	7/8 X 4.75	M22 X 120	24			
	ANSI 300	1 1/8 X	M27 X 170	32			
	PN 16		M24 X 115	24			
	PN 40		M30 X 160	32			

#### 4 QUICK-CHECK

Before commissioning, check the control valve by following these steps:

- 4.1 Check for full stroke by varying the instrument signal settings appropriately. Observe the plug position indicator located on the actuator or the positioner. The plug should change position with a smooth turning movement.
- 4.2 Check all air connections for leaks. Tighten or replace any leaking lines.

- 4.3 Check packing box bolting for proper tightness.



**CAUTION:** Do not overtighten packing. This can cause excessive packing wear and high stem friction that may impede shaft movement. After the valve has been in service for a short period, recheck the packing-box nuts. If the packing-box leaks, tighten the nuts just enough to stop the leak.

- 4.4 Make sure the valve fails in the correct direction in case of air failure. This is done by positioning the valve at mid-stroke and turning off the air supply and observing the failure direction. If the action is incorrect, see the section "Reversing the Air-action" in the instructions of the installation, operation and maintenance manual of the appropriate actuator.

#### 5 PREVENTATIVE MAINTENANCE

At least once every six months, check for proper operation by following the preventative maintenance steps outlined below. These steps may be performed while the valve is in-line and without interrupting service. If an internal problem is suspected, refer to section "Valve Disassembly".

- 5.1 Look for signs of gasket leakage through the end flanges and bonnet. If necessary, re-torque flange, bonnet and post bolting.
- 5.2 Examine the valve for damage caused by corrosive fumes or process drippings.
- 5.3 Clean the valve and repaint areas of severe oxidation.
- 5.4 Check the packing-box for proper tightness. If there is a persistent leak, change the packing after referring to sections "Valve Disassembly and Body Reassembly".



**CAUTION:** Do not overtighten packing. This can cause excessive packing wear and high friction that may impede shaft movement.

- 5.5 If the valve is equipped with a lubricator, add lubricant if necessary.
- 5.6 If possible, stroke the valve and check for smooth, full-stroke operation. Unsteady shaft movement may indicate an internal valve problem.
- 5.7 Check the calibration of the positioner. For further preventative maintenance, see the instructions in the installation, operation and maintenance manual for the applicable positioner.
- 5.8 Ensure all accessories, brackets and bolting are securely fastened.
- 5.9 If possible, remove air supply and observe actuator for correct fail-safe action.
- 5.10 Check the actuator and all air connections for leaks.
- 5.11 If an air filter is supplied, check and replace the cartridge if necessary.

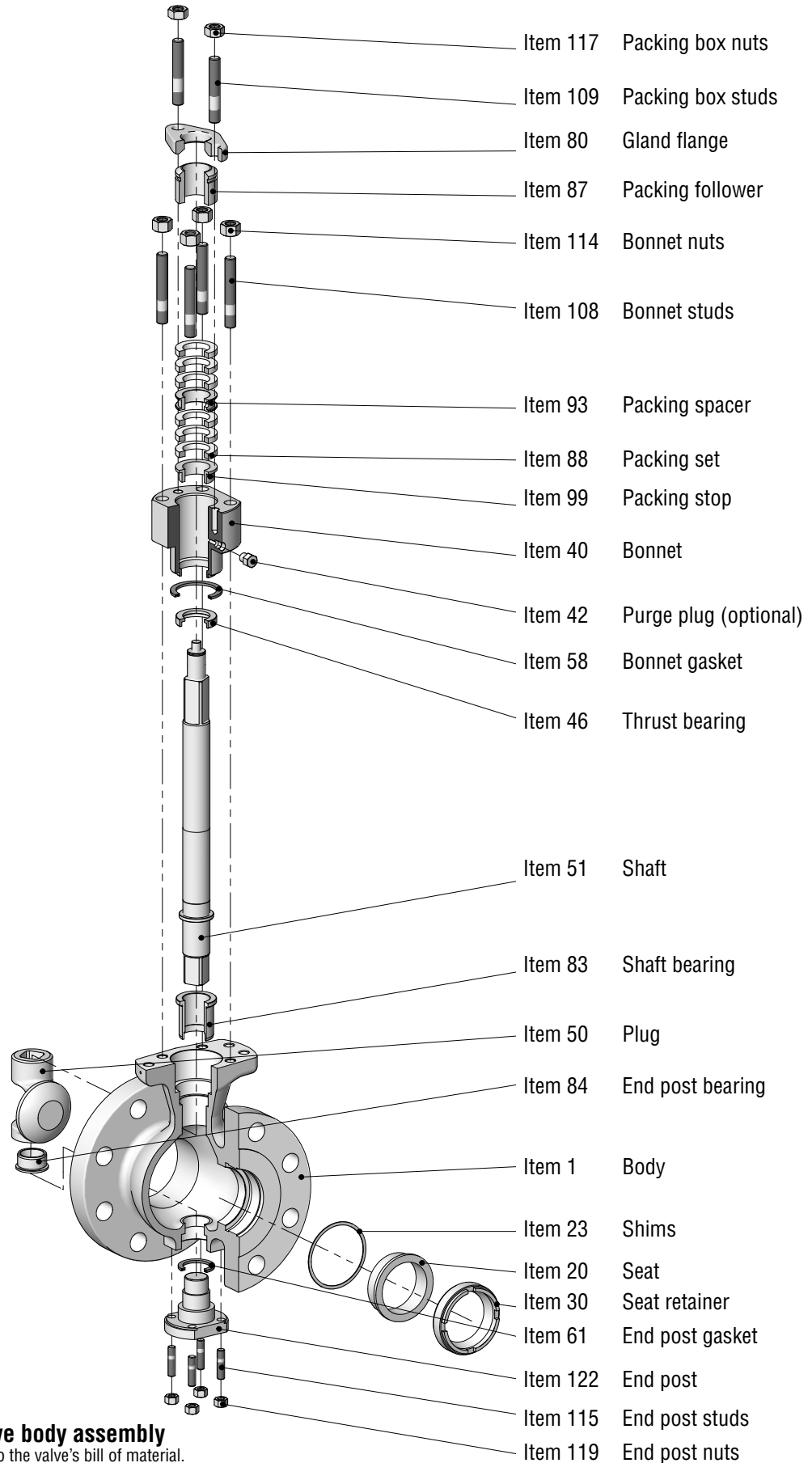

**Figure 1: MaxFlo 3 valve body assembly**  
 item numbers correspond directly to the valve's bill of material.  
 Refer to it for specific part numbers.

## 6 VALVE DISASSEMBLY



**WARNING:** To carry out this operation, it is essential to disconnect the valve from the pipework. Depressurize line to atmospheric pressure and drain all fluids before working on the valve. Failure to do so can cause serious injury. Remove the valve from the pipeline.

Refer to figure 1 to find parts according to the item numbers.

- 6.1 Remove the actuator from the body by separating the actuator at the yoke. Refer to the installation, operation and maintenance manual for the corresponding actuator.
  - 6.2 Remove the four bonnet nuts (item 114).
  - 6.3 Remove the packing nuts and gland flange (item 80).
  - 6.4 Carefully pull the shaft (item 51) out of the body. The bonnet, thrust bearing, packing stop and packing will all slide out of the body bore as an assembly.
- ! **NOTE:** At this point in the disassembly operation, the plug is inside the valve body and is only supported by the end post. When removing the end post, support the plug so it does not drop into the bottom of the valve body.
- 6.5 Remove the end post nuts (item 119) and carefully remove the end post (item 122) from the body.
  - 6.6 Remove the plug from the body. See figure 2a.
  - 6.7 Loosen the packing-box nuts (item 117) and remove the shaft from the bonnet by sliding it out slowly. The thrust bearing (item 46) and the shaft stop spacer (item 47, only for sizes 10 to 12") can now be removed from the shaft.
  - 6.8 Remove the packing follower (item 87) as well as the packing (item 88), spacers (item 93) and the packing stop (item 99).
  - 6.9 Remove the bonnet gasket (item 58) and end post gasket (item 61). Clean all bearing and seal surfaces.
  - 6.10 Remove the shaft bearing (item 83) from the valve body. Use a suitable dowel to push the bearing out if necessary. Be careful not to damage the bearing.
  - 6.11 Unscrew the seat (item 30) using the appropriate tool (see Table IV) and remove the seat (item 20) as well as the adjustment shims (item 23).

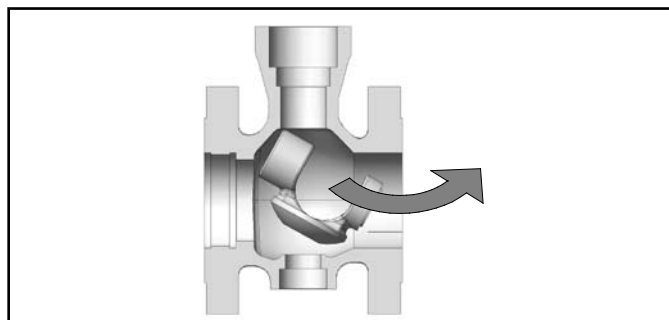

Figure 2a: Plug Removal

## 7 BODY REASSEMBLY



**NOTE:** Lubricate all threads, bearings and the shaft shoulder with a boron nitride paste (Molydal NB1200) or a nickel anti-seize lubricant (Permatex 77164 or equivalent). Place the valve body in a vice and clamp securely in a vertical position.

- 7.1 Always use new packing and gaskets when reassembling a valve.
  - 7.2 Make sure that the shaft, bonnet bore and gasket surfaces in the body have been thoroughly cleaned (these are sealing surfaces and it is important to remove any contamination before reassembly).
  - 7.3 Make sure that all bearing surfaces have been cleaned.
  - 7.4 Install all end post (item 115) and bonnet (item 108) studs.
  - 7.5 Insert the plug in the body as shown in figure 2b.
- ! **NOTE:** The end post bearing (item 84) is pressed into the plug.
- 7.6 Place the end post gasket (item 61) on the end post (item 122). Insert the end post into the small flanged port in the end of the body. As the end post is inserted, locate the plug (item 50) so the end post will insert into the end post bearing located in the plug.
- ! **NOTE:** For valves 3" and larger, insert the end post with the milled faces parallel to the flanges of the valve body.
- 7.7 Tighten the end post nuts to finger tight.
  - 7.8 Insert the shaft bearing (item 83) into the body until the shoulder on the bearing contacts the step in the valve body. The bearing will protrude slightly into the body gallery area.
  - 7.9 Place the thrust bearing onto the shaft. Slide it up to the thrust runner. The shaft thrust bearing will surround the thrust runner.
- ! **NOTE:** for sizes 10" and 12", an end spacer (item 47) is placed above the thrust bearing.

Table II: Nut tightening torques for bonnet and post

Stud Size	A193-B7	A193-B8 cl2	A453-Gr660 (Nace)
M8	12 ft-lb / 16 Nm	7.5 ft-lb / 10 Nm	10.5 ft-lb / 14 Nm
M12	43.5 ft-lb / 59 Nm	27.5 ft-lb / 37 Nm	30.5 ft-lb / 41 Nm
M16	62.5 ft-lb / 85 Nm	39 ft-lb / 53 Nm	43.5 ft-lb / 59 Nm

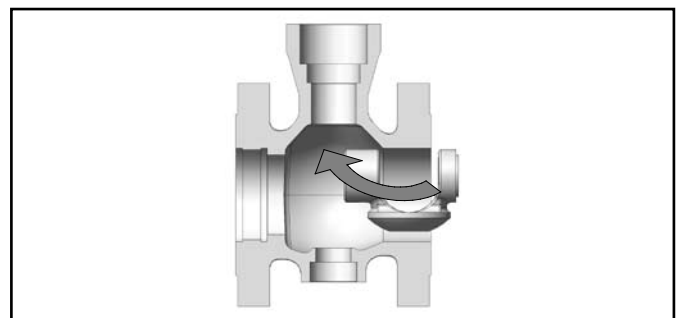

Figure 2b: Plug Installation

7.10 Place the bonnet gasket (item 58) on the gasket step inside the body. Gently push the bonnet into the bonnet bore.

! **NOTE:** When installing the bonnet, orient the milled faces on the bonnet perpendicular to the flanges of the valve body.

7.11 Place the packing stop (item 99) into the bonnet, then install the packing spacer (item 93) and packing as shown in figure 3.

7.12 Install bonnet nuts and tighten to finger tight.

7.13 Install the packing follower (item 87) and gland flange (item 80), then tighten the packing nuts to finger tight.

7.14 Tighten the bonnet and end post nuts evenly. Torque nuts to the values listed in table II.

7.15 Install the shims (item 23) and seat ring (item 20) as described in the Seat Replacement section.

7.16 Install the actuator and yoke as described in the installation manual for the corresponding actuator.

7.17 Install the valve into the process line as described in the installation section.

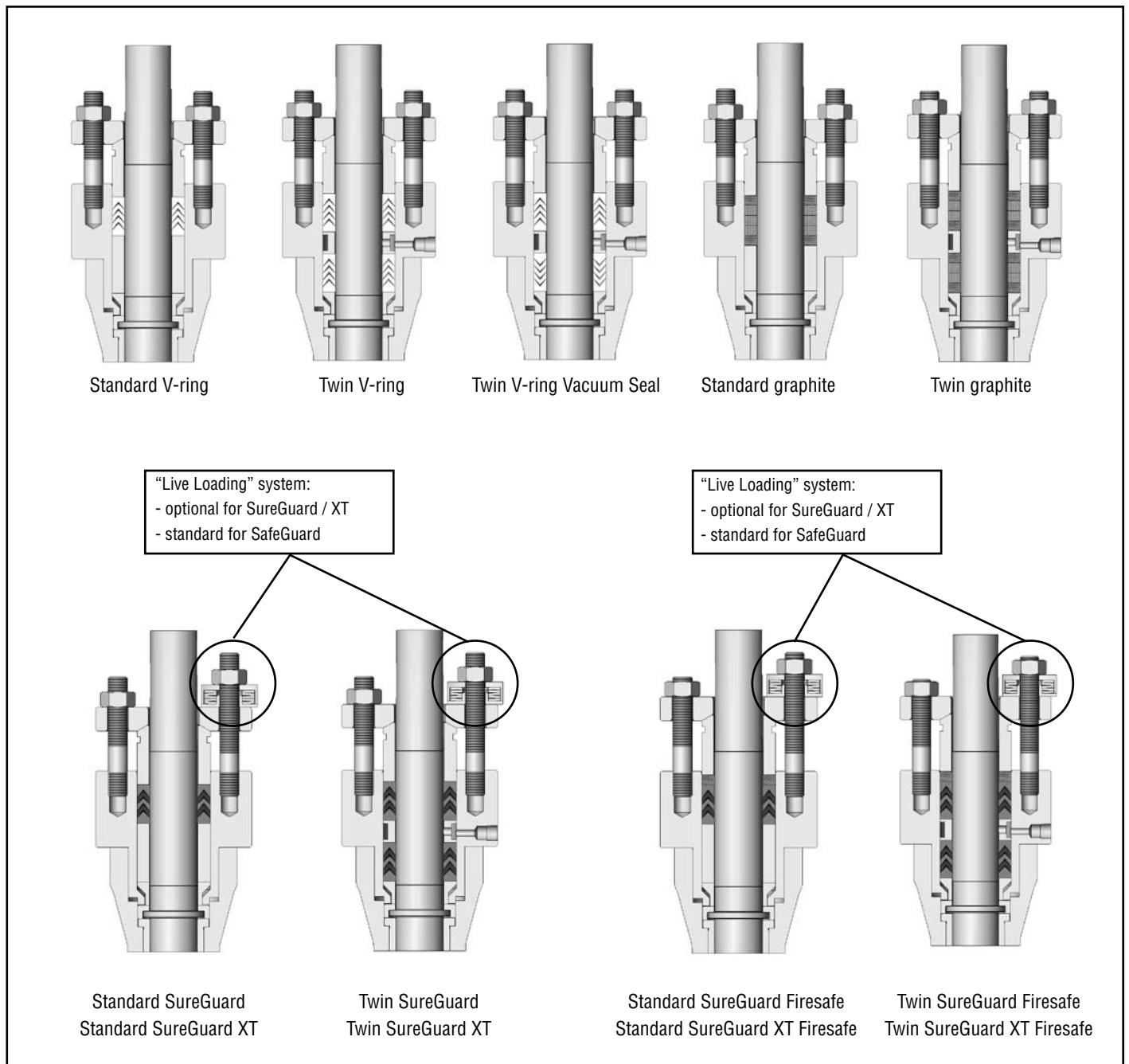

Figure 3: Packing Configurations

## 8 SEAT REPLACEMENT



**WARNING:** The actuator must be removed from the valve body prior to replacing the seat ring.

- 8.1 To replace the seat, see figures 4 and 5, and proceed as follows:
- 8.2 Loosen the packing box nuts.
- 8.3 Using the appropriate retainer tool (see Table III), remove the seat retainer. (Retainer tools are available from the factory).
- 8.4 Remove the seat and any shims that may be installed under the seat.
- 8.5 Check both seat and plug surfaces for wear and galling. Replace these parts if necessary.
- 8.6 Clean seat ring, seat retainer and body threads of old sealant residue. Clean parts thoroughly.
- 8.7 To reinstall the seat, place the seat (without shims) into the valve body. Rotate the plug to 90 degrees open. Measure dimension "A" as shown in figure 4a.

- 8.8 Close the plug into the seat and then measure dimension "B" as shown in figure 4b.



**NOTE:** For optimum sealing do not over-rotate the plug into the seat. A very slight under-rotation is recommended. (See figure 5)

- 8.9 The difference between dimension "A" and "B" represents the total thickness of the adjustment shims to be added between the seat and the valve body. See table III to select the necessary shim(s). Regardless of the valve size, at least one shim must be present.
- 8.10 Remove the seat and add the appropriate number of shims. (Flowserve recommends a sealant with a temperature range of -70 to 200 °C, type Dow Corning RTV 736, or a sealant with a graphite base for higher temperatures or for steam processes.)
- 8.11 Apply lubricant to the threads of the seat retainer. Replace the seat retainer and tighten manually until it makes contact with the seat, then loosen it by 1/8 of a turn. Open and close the valve several times while tightening the seat retainer manually to position the seat correctly. Finally, close the valve and tighten the seat retainer according to the values in table IV.

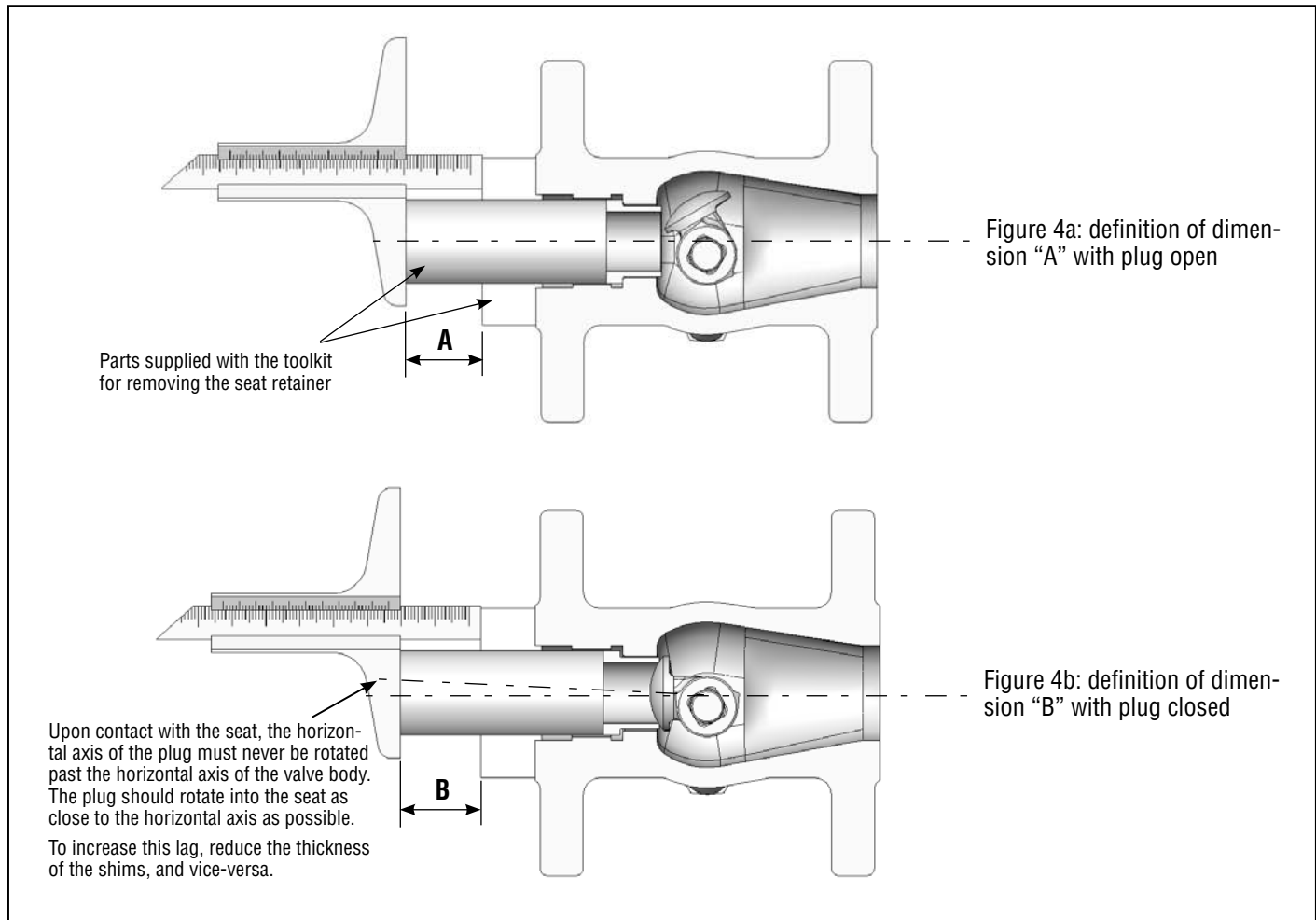

Figure 4: shimming the seat



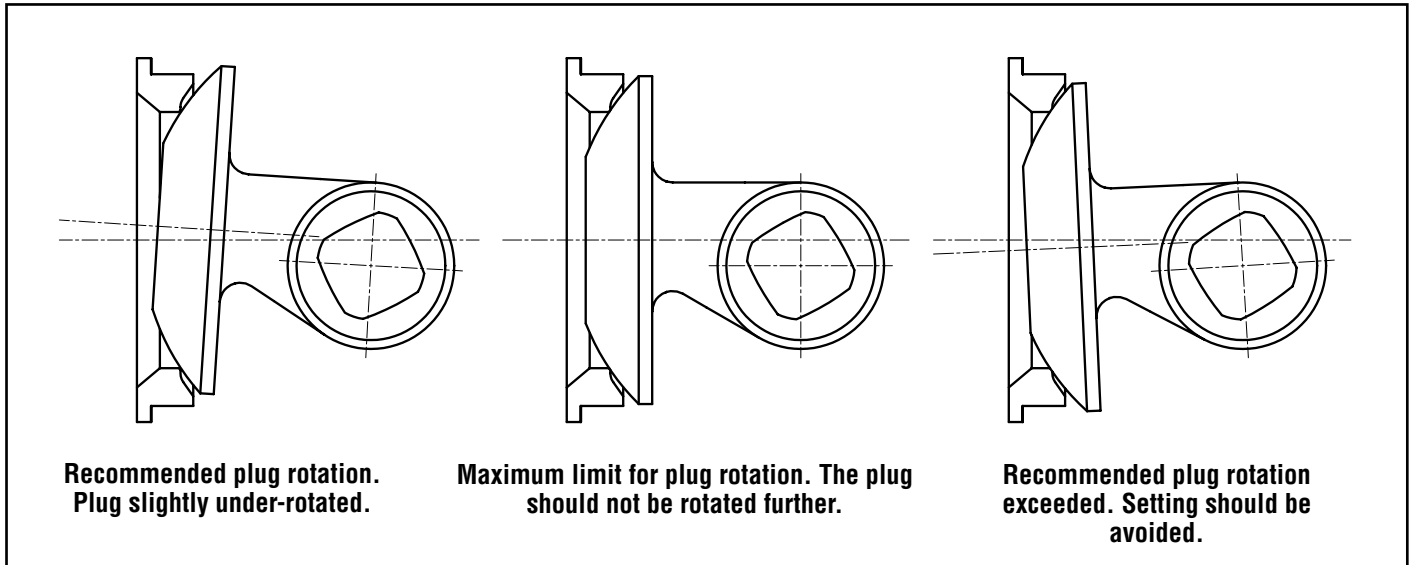

Figure 5: positioning of plug

Table III: Shim Selection

Valve Size	Rounding rule	Example	Chosen thickness	Thickness of shims available				
				0.1 mm	0.15 mm	0.2 mm	0.3 mm	0.5 mm
1" DN25	to 0.05 mm	A – B = 0.27 mm rounded to 0.25 mm	0.1 mm 0.15 mm	X	X	X		X
1.5" to 8" DN40 à DN200	to 0.1 mm	A – B = 0.27 mm rounded to 0.2 mm	0.2 mm	X		X	X	X
10" – 12" DN250 – DN300	A - B - 0.3 rounded to 0.5mm	A – B = 0.9 mm A – B – 0.3 mm = 0.6 mm	0.5 mm	X		X		X

Table IV: Seat Retainer Removal Tools and Required Torque Values

Valve size	Face-to-Face	
	ANSI/ISA-75.08.02, EN 558.1/2 series 36, IEC 60534-3-2, DIN 3202 F1, EN 558-1/2 series 1	ANSI/ISA-75.08.0, EN 558-1/2 series 37-38, IEC 60534-3-1
1" DN 25	Part number: 183224.999.000 Torque: 41 ft-lbs / 55 Nm	
1.5" DN 40	Part number: 183225.999.000 Torque: 103 ft-lbs / 140 Nm	
2" DN 50	Part number: 183226.999.000 Torque: 155 ft-lbs / 210 Nm	
3" DN 80	Part number: 183227.999.000 Torque: 406 ft-lbs / 550 Nm	
4" DN 100	Part number: 183228.999.000 Torque: 428 ft-lbs / 580 Nm	
6" DN 150	Part number: 183229.999.000 Torque: 959 ft-lbs / 1300 Nm	
8" DN 200	Part number: 183230.999.000 Torque: 701 ft-lbs / 950 Nm	Part number: 183229.999.000 Torque: 959 ft-lbs / 1300 Nm
10" DN 250	Part number: 183231.999.000 Torque: 553 ft-lbs / 750 Nm	Part number: 183230.999.000 Torque: 701 ft-lbs / 950 Nm
12" DN 300	Part number: 183232.999.000 Torque: 752 ft-lbs / 1020 Nm	Part number: 183231.999.000 Torque: 553 ft-lbs / 750 Nm

## 9 ACTUATOR REMOUNTING

! **NOTE:** The MaxFlo 3 valve opens in a clockwise direction when looking down the valve shaft.

9.1 When remounting the actuator to the valve, refer to the appropriate actuator manual.

! **NOTE:** The actuator stroke stops must be adjusted correctly to avoid any over-rotation of the plug stroke. Poor adjustment can cause damage to the valve. Pay special attention to the adjustment of the closing stop when the valve has a soft seat.

9.2 Install the valve in the pipeline as indicated in the "Installation" section according to the orientation recommendations given at the end of the manual.

## 10. PRINCIPLES OF SHAFT ANTI-BLOWOUT SYSTEM

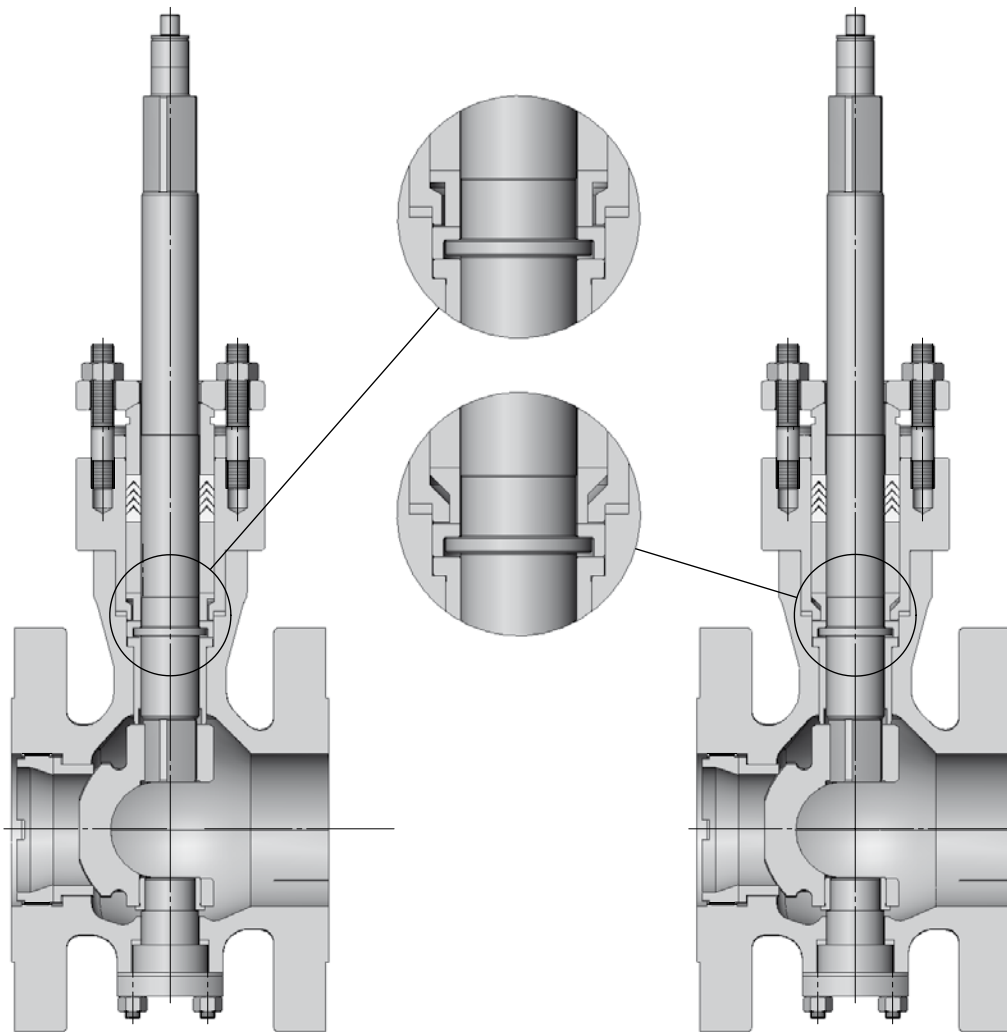

Figure 6a: old design

Figure 6b: new design

! **NOTE:** The MaxFlo 3 valve has been significantly improved, with even greater safety for the anti-blowout system.

The diameter of the shaft shoulder exceeds the diameter of the bonnet bore. Even if the thrust bearing (item 46) is not installed during reassembly, the shaft cannot pass through the bonnet.

It is possible to upgrade from the old design (prior to mid-2006) by changing the bonnet (40) and the packing stop (99).

**To order the correct replacement parts, contact your Flowserve representative with the serial numbers of the valves requiring the upgrade.**

## 11. PIPELINE MOUNTING ORIENTATIONS – AIR-TO-OPEN CONFIGURATION - DIAPHRAGM ACTUATOR

		AIR-TO-OPEN, FAIL CLOSE CONFIGURATION			
		SHAFT DOWNSTREAM		SHAFT UPSTREAM	
<b>HORIZONTAL FLOW</b>					<b>LEFT HAND PIPE MOUNTING</b>
					<b>RIGHT HAND PIPE MOUNTING</b>
<b>VERTICAL FLOW</b>					<b>FLOW DOWN</b>
					<b>FLOW UP</b>

12. PIPELINE MOUNTING ORIENTATIONS – AIR-TO-CLOSE CONFIGURATION - DIAPHRAGM ACTUATOR

		AIR-TO-CLOSE, FAIL OPEN CONFIGURATION			
		SHAFT DOWNSTREAM		SHAFT UPSTREAM	
<b>HORIZONTAL FLOW</b>					<b>LEFT HAND PIPE MOUNTING</b>
					<b>RIGHT HAND PIPE MOUNTING</b>
<b>VERTICAL FLOW</b>					<b>FLOW DOWN</b>
					<b>FLOW UP</b>

## 13: PIPELINE MOUNTING ORIENTATIONS – AIR-TO-OPEN CONFIGURATION - CYLINDER ACTUATOR

		AIR-TO-OPEN, FAIL CLOSE CONFIGURATION			
		SHAFT DOWNSTREAM		SHAFT UPSTREAM	
<b>HORIZONTAL FLOW</b>					<b>LEFT HAND PIPE MOUNTING</b>
					<b>RIGHT HAND PIPE MOUNTING</b>
<b>VERTICAL FLOW</b>					<b>FLOW DOWN</b>
					<b>FLOW UP</b>

**14: PIPELINE MOUNTING ORIENTATIONS – AIR-TO-CLOSE CONFIGURATION - CYLINDER ACTUATOR**

		AIR-TO-CLOSE, FAIL OPEN CONFIGURATION			
		SHAFT DOWNSTREAM		SHAFT UPSTREAM	
<b>HORIZONTAL FLOW</b>	<b>LEFT HAND PIPE MOUNTING</b>				
	<b>RIGHT HAND PIPE MOUNTING</b>				
<b>VERTICAL FLOW</b>	<b>FLOW DOWN</b>				
	<b>FLOW UP</b>				

### 15 PIPE MOUNTING ORIENTATION CODES

3 - Air Action		4 - Pipe Configuration		5 - Actuator Orientation		6 - Shaft Direction	
<b>O</b>	Air-to-open - ATO	<b>L</b>	Left Hand Mounting	<b>L</b>	Left	<b>U</b>	Shaft Upstream
<b>C</b>	Air-to-close - ATC	<b>R</b>	Right Hand Mounting	<b>R</b>	Right	<b>D</b>	Shaft Downstream
		<b>D</b>	Flow Down	<b>T</b>	Top (Default)		
		<b>U</b>	Flow Up	<b>B</b>	Bottom*		

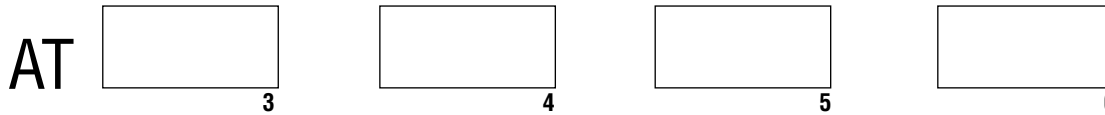

\* Not available on diaphragm actuators

### 16. TROUBLESHOOTING

Failure	Probable Cause	Corrective Action
Valve moves to failure position, excessive air bleeding from transfer case	1. Failure of cylinder actuator O-ring	1. Replace actuator O-ring
	2. Failure of sliding seal assembly in cylinder actuator	2. Repair or replace sliding seal assembly
Jerky shaft rotation	1. Overtightened packing	1. Retighten packing box nuts to slightly over finger-tight for V-ring packing, 14 ft-lbs/19 Nm for braided packing.
	2. Improper adjustment of lever arm on shaft causing arm to contact transfer case	2. Redjust lever arm (see step 1 in Actuator Remounting)
	3. Cylinder wall of actuator not lubricated	3. Lubricate cylinder wall with silicone lubricant
	4. Worn piston O-ring allowing piston to gall on cylinder wall	4. Replace O-ring; if galling has occurred replace all damaged parts
	5. Worn actuator stem O-ring causing actuator stem to gall on stem collar	5. Replace O-ring; if actuator stem is galled replace it
	6. Worn (or damaged) thrust bearings, shaft bearing or packing followers	6. Disassemble and inspect parts; replace any worn or damaged parts
Excessive leakage	1. Improper adjustment of external stroke stops	1. See Actuator Remounting
	2. Improper seat adjustment	2. See Seat Replacement
	3. Worn or damaged seat	3. Replace seat
	4. Damaged plug seating surface	4. Replace plug
	5. Improper handwheel adjustment acting as limit stop	5. Adjust handwheel until plug seats properly
Leakage through line flanges	1. Dirty line gasket surfaces	1. Clean gasket surfaces and reinstall valve
	2. Improper sealing of line flanges	2. Tighten line flanges evenly and completely (see Table 1 for proper torque)
	3. Flange or pipe misalignment	3. Reinstall valve in line; check piping system
Leakage through packing box	1. Loose packing box nuts	1. Tighten packing box nuts to slightly over finger-tight for V-ring packing, 14 ft-lbs/19 Nm for braided packing.
	2. Worn or damaged packing	2. Replace packing
	3. Dirty or corroded packing	3. Clean body bore and stem, replace packing
Valve slams, wont open, or causes severe water hammer	1. Improper valve installation	1. See step 2 in Installation and correct flow direction
Shaft rotates, plug remains open or closed	1. Broken shaft	1. Replace shaft, make sure plug does not overstroke and contact plug stop
Actuator operates, shaft does not rotate	1. Broken internal actuator parts	1. Refer to appropriate actuator maintenance instructions
Leakage through bonnet joint; leakage from end post	1. Loose bolting or damaged gasket	1. Tighten bolting as recommended in Table II
	2. Dirty gasket surfaces	2. Clean gasket surfaces, replace gaskets and retighten bolting per Table II



**Flowserve Corporation  
Flow Control**  
1350 N. Mt. Springs Parkway  
Springville, UT 84663  
USA  
Phone: 801 489 8611  
Fax: 801 489 3719

**Flowserve S.A.S.**  
12, avenue du Quebec  
B.P. 645  
91965 Courtaboeuf Cedex  
France  
Phone: 33 (0) 1 60 92 32 51  
Fax: 33 (0) 1 60 92 32 99

**Flowserve Pte Ltd.**  
12 Tuas Avenue 20  
Singapore 638824  
Singapore  
Phone: 65 6868 4600  
Fax: 65 6862 4940

**Flowserve Australia Pty Ltd.**  
14 Dalmore Drive  
Scoresby, Victoria 3179  
Australia  
Phone: 61 7 32686866  
Fax: 61 7 32685466

**Flowserve Ltda.**  
Rua Tocantins, 128  
São Caetano do Sul, SP 09580-130  
Brazil  
Phone: 55 11 2169 6300  
Fax: 55 11 2169 6313

FCD VLAIM0052-01 – 02/07 (Replaces VLAIM052-00)

To find your local Flowserve representative please use the Sales Support Locator System found at:

[www.flowserve.com/contact.htm](http://www.flowserve.com/contact.htm)

or call USA 801 489-8611

Flowserve Corporation has established industry leadership in the design and manufacture of its products. When properly selected, this Flowserve product is designed to perform its intended function safely during its useful life. However, the purchaser or user of Flowserve products should be aware that Flowserve products might be used in numerous applications under a wide variety of industrial service conditions. Although Flowserve can (and often does) provide general guidelines, it cannot provide specific data and warnings for all possible applications. The purchaser/user must therefore assume the ultimate responsibility for the proper sizing and selection, installation, operation, and maintenance of Flowserve products. The purchaser/user should read and understand the Installation Operation Maintenance (IOM) instructions included with the product, and train its employees and contractors in the safe use of Flowserve products in connection with the specific application.

While the information and specifications contained in this literature are believed to be accurate, they are supplied for informative purposes only and should not be considered certified or as a guarantee of satisfactory results by reliance thereon. Nothing contained herein is to be construed as a warranty or guarantee, express or implied, regarding any matter with respect to this product. Because Flowserve is continually improving and upgrading its product design, the specifications, dimensions and information contained herein are subject to change without notice. Should any question arise concerning these provisions, the purchaser/user should contact Flowserve Corporation at any one of its worldwide operations or offices.

© 2006 Flowserve Corporation, Irving, Texas, USA. Flowserve is a registered trademark of Flowserve Corporation.